

3 FACILE

Special Pergola System

OPEN & CLOSE
APRI & CHIUDI



3 Facile Open&Close is the only aluminium pergola on which it is possible to install 2 different types of top cover, independent one from the other and fully open/close.

A unique structure able to offer a total protection and a comfortable environment thanks to the double function sun protection and rain protection.

The exclusive opening and closing system, manual or motorized, allows to both top covers an easy and fast movement.

3 Facile Apri&Chiudi è l'unica pergola in alluminio presente sul mercato nella quale è possibile installare due diversi tipi di copertura indipendenti fra loro e completamente apri/chiodi.

Un'unica struttura in grado di fornire una protezione totale ed un ambiente confortevole grazie alla doppia funzione parasole e parapiovvia.

L'esclusivo sistema di movimentazione, manuale o motorizzato, permette per entrambe le coperture una pratica apertura e chiusura in tempi rapidissimi.



GIULIO BARBIERI
Special Modular Coverings

giulio barbieri@giulio barbieri.it

www.giulio barbieri.it

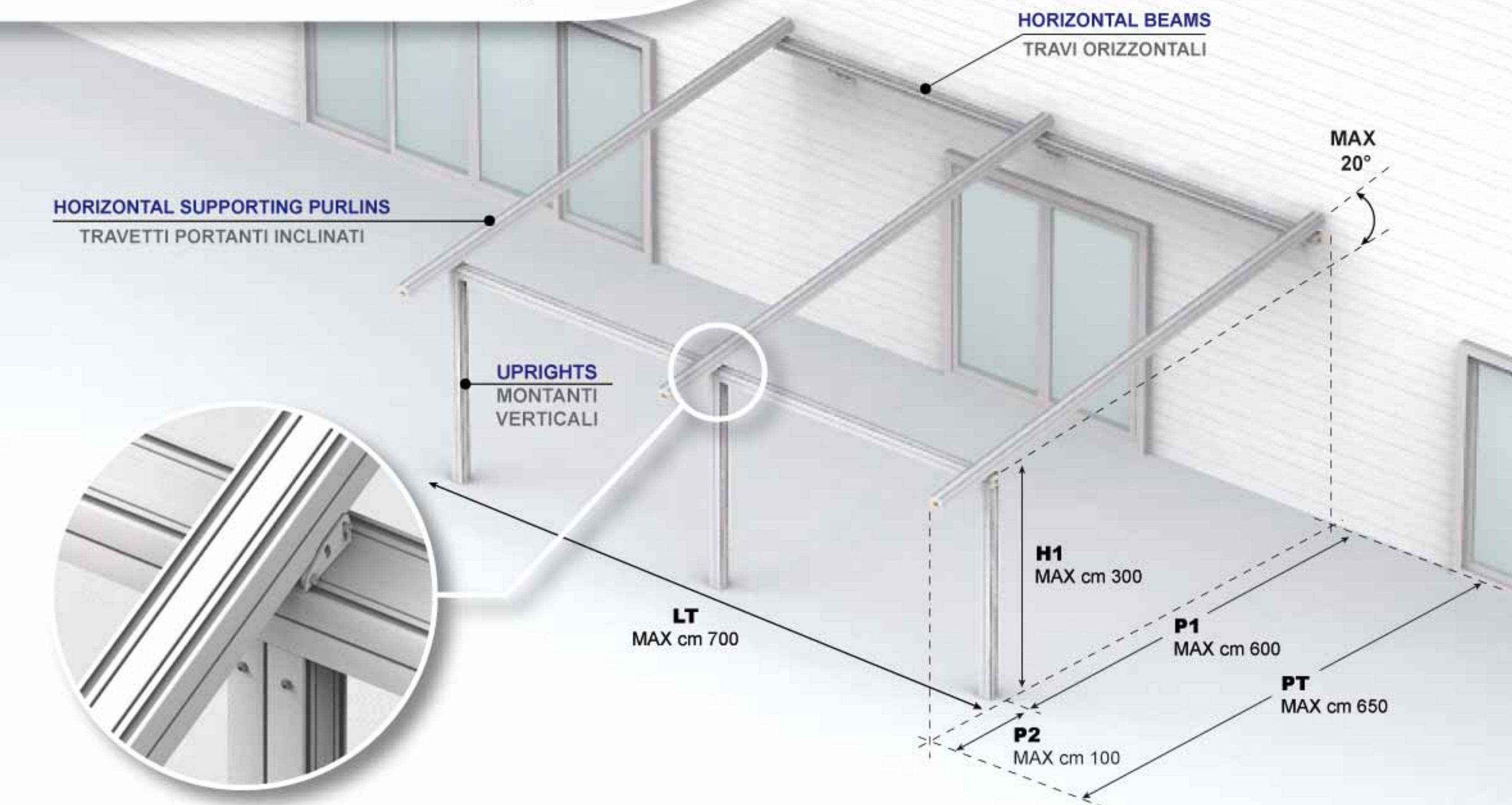
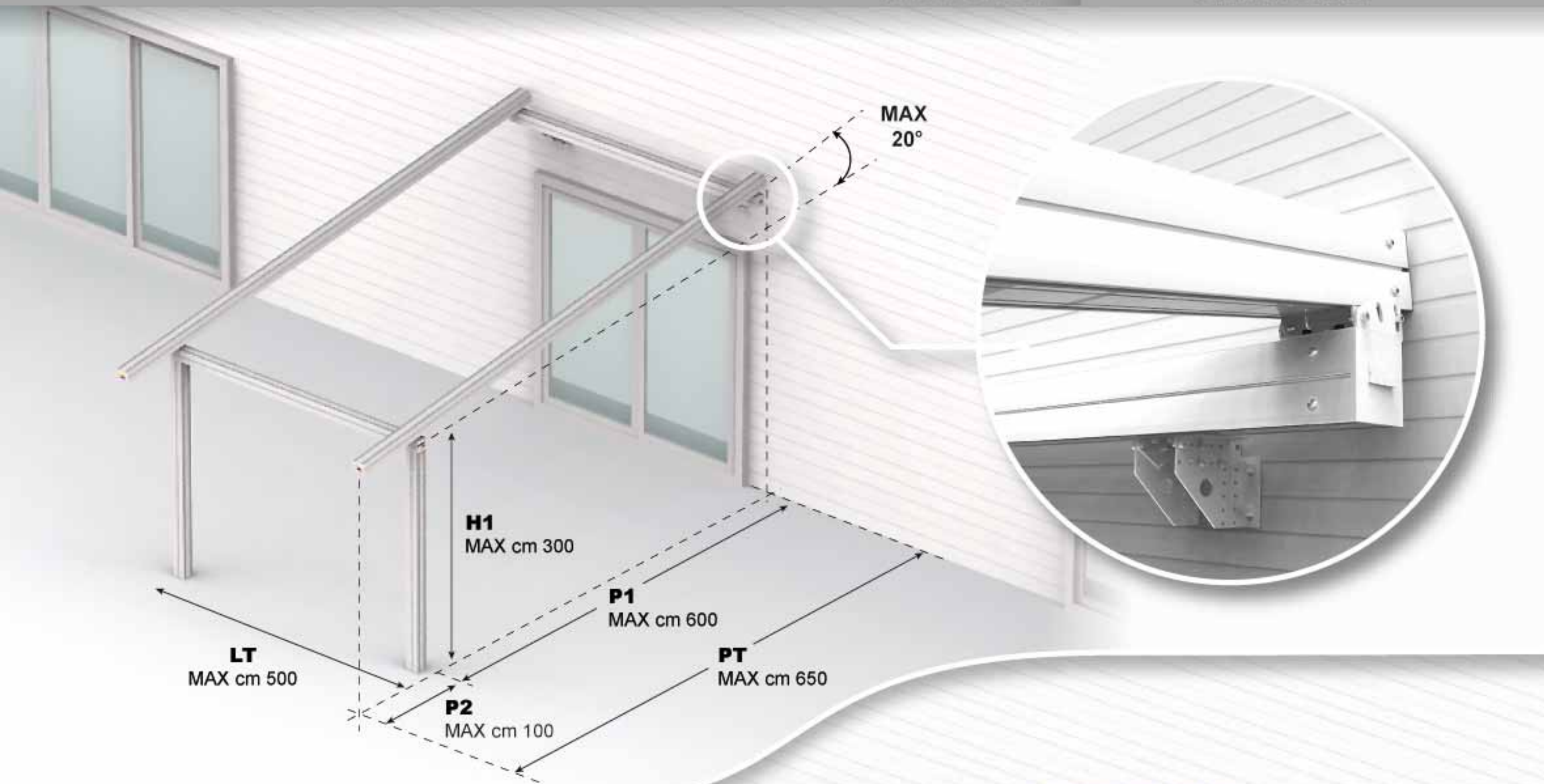

**IS COMPOSED BY ONLY THREE STRUCTURAL ELEMENTS:
E' COMPOSTA DA SOLI 3 ELEMENTI STRUTTURALI:**

1

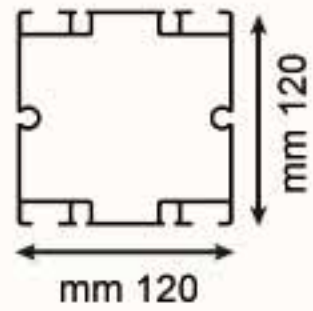

UNIVERSAL PROFILE:

The uprights, the horizontal beams as well as the horizontal supporting purlins are realized with the same aluminium profile, solid and sturdy.

PROFILO UNIVERSALE:

I montanti verticali, le travi orizzontali così pure i travetti portanti orizzontali sono realizzati da un unico profilo di alluminio solido e robusto.

**STANDARD COLOURS
COLORI STANDARD**



2

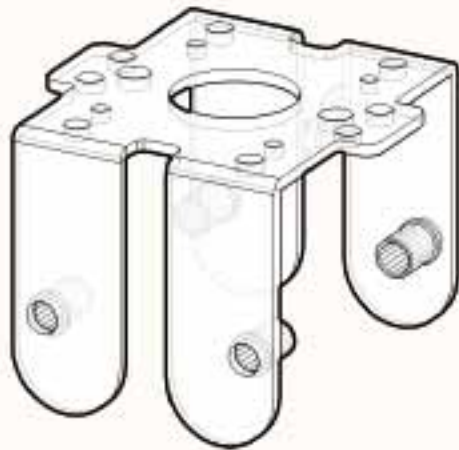

UNIVERSAL BRACKET:

The universal bracket is located at the ends of each profile and enables the connection between the right angle profiles by means of proper connecting plates.

It's possible to connect the profiles by opposing the two universal brackets. The anchoring plates and the closing taps are connected to the universal bracket as well.

STAFFA UNIVERSALE:

La staffa universale è collocata alle estremità di ogni profilo e con l'ausilio di apposite piastrine permette la congiunzione fra i profili ad angolo retto. Contrapponendo invece le due le staffe universali con viti è possibile unire i profili fra loro. Alla staffa universale vengono applicate inoltre le piastre di ancoraggio al suolo e tappi di chiusura profili.

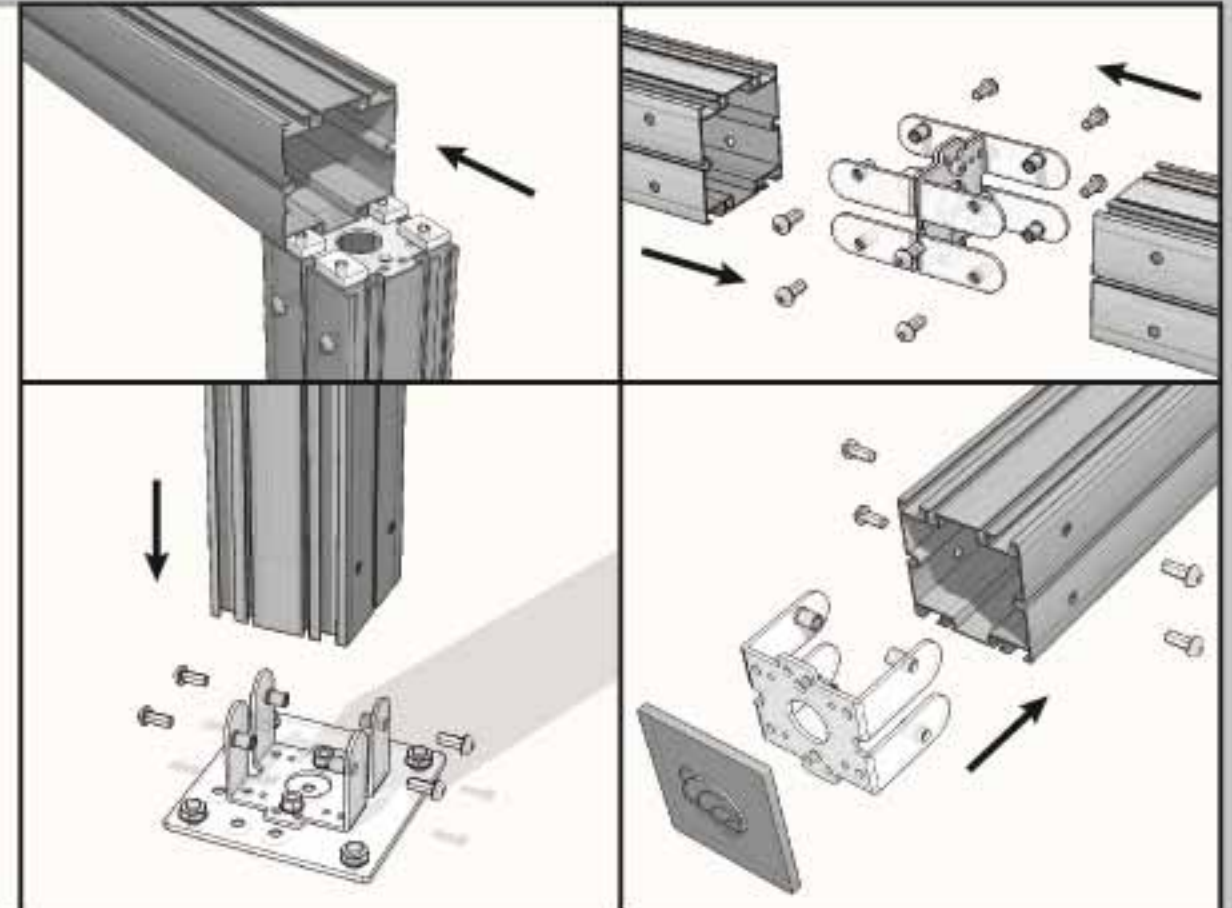

3

**quick connection clamp
aggancio rapido a morsa**

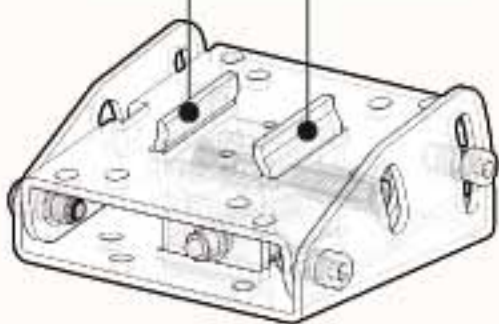

HINGE:

The hinge enables to adjust the angle of the supporting purlins up to 20° and links the horizontal beams through a specially designed quick connection. The hinge can slide in both directions, longitudinal and transversal, inside the grooves of the universal profile before being fastened. This possibility enables the easy stretching of the canvas as well as the adjustment of the projecting part.

CERNIERA:

La cerniera, oltre a consentire l'inclinazione fino a 20° dei travetti portanti, ha la funzione di congiunzione, per mezzo di uno speciale aggancio rapido, alle travi orizzontali. La cerniera è caratterizzata dal fatto che, prima del serraggio, essa possa scorrere sia nel senso longitudinale che trasversale, all'interno di apposite scanalature ricavate nel profilo universale. Ciò facilita il tensionamento del telo e la variazione della parte a sbalzo.

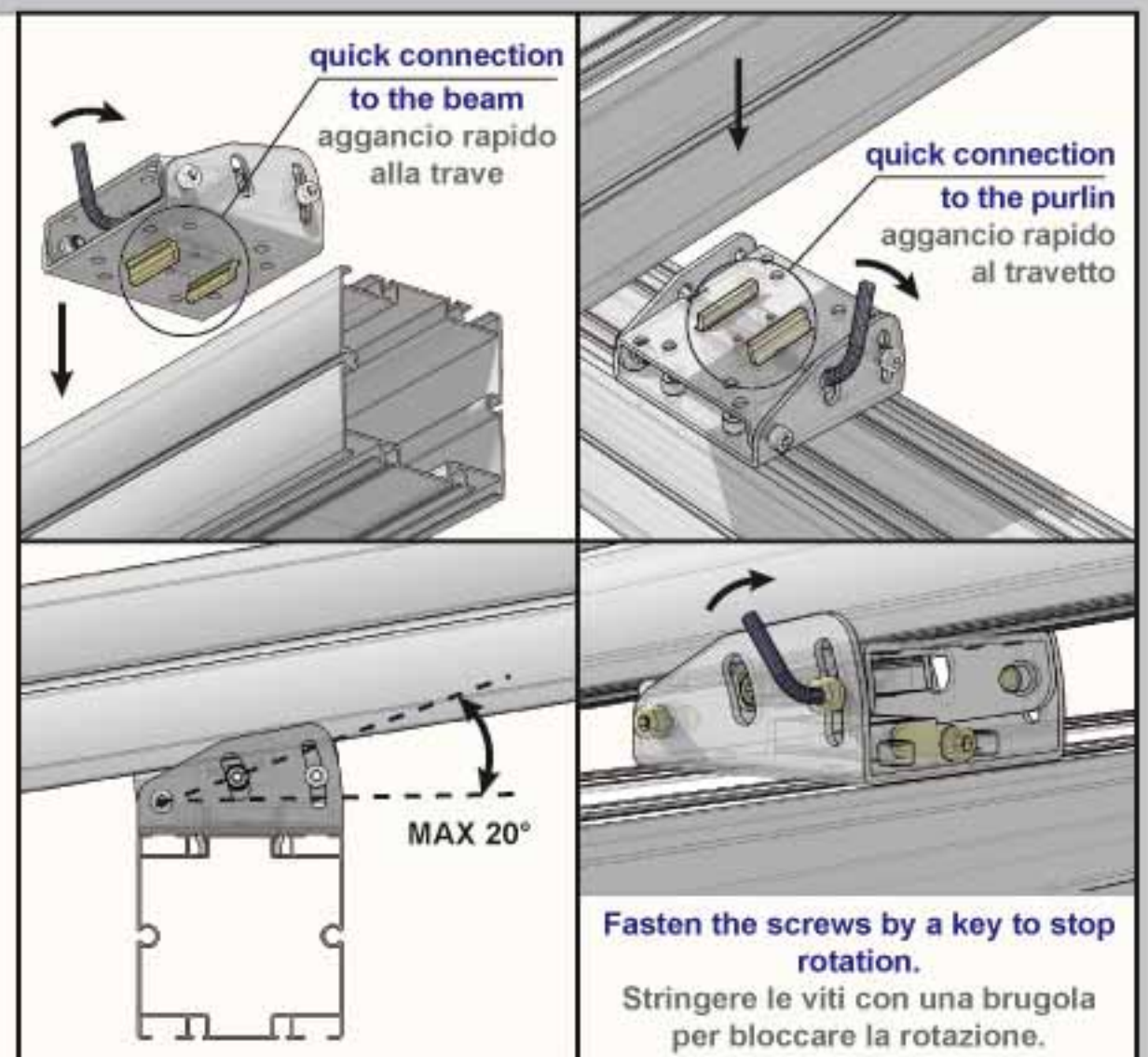

ADJUSTABLE FASTENING SYSTEM TO THE WALL
SISTEMA DI FISSAGGIO REGOLABILE A PARETE

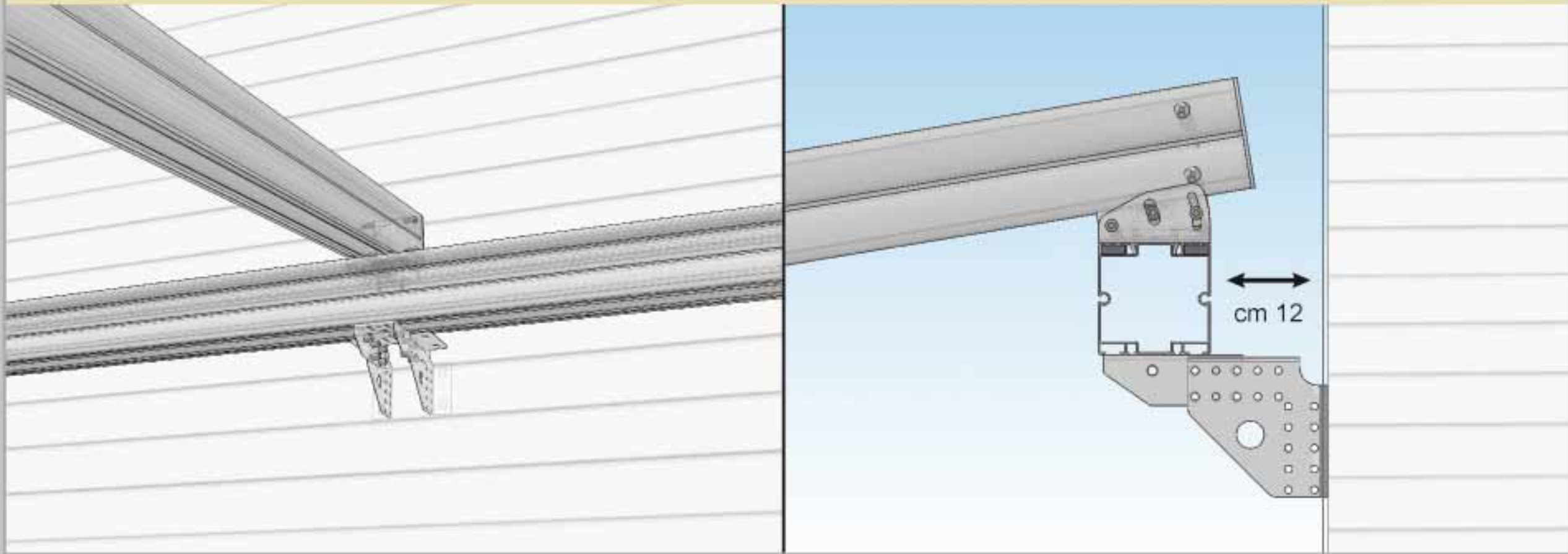

ANCHORING TO THE GROUND
SISTEMA DI FISSAGGIO AL SUOLO

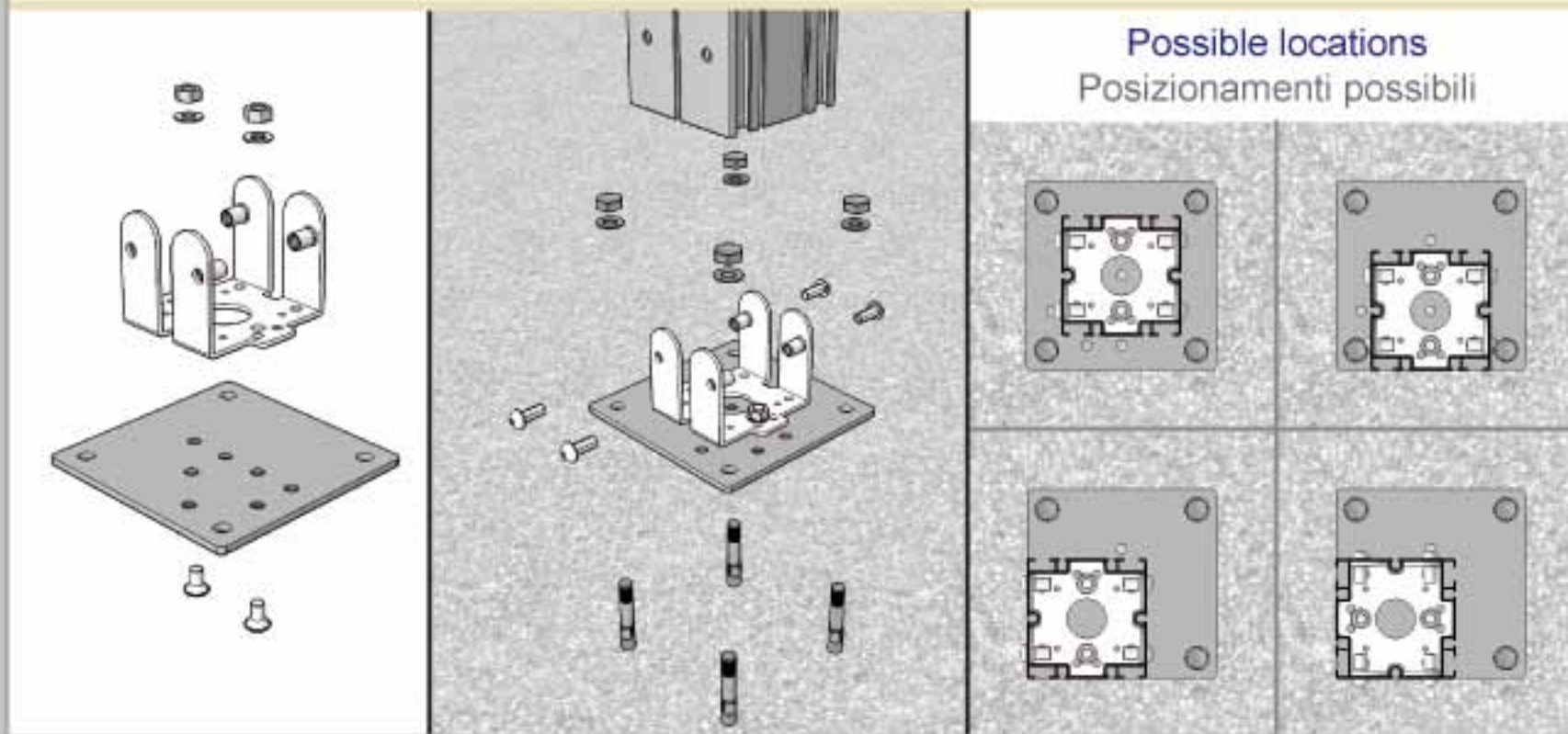

OPTIONAL

GABLE END
TIMPANO



SELF-SUPPORTING MODEL
VERSIONE AUTOPORTANTE





OPEN & CLOSE
SUN PROTECTION

APRI & CHIUDI
PARASOLE

The Sun Protection version foresees the installation, on the interior side of the top cover, of a mobile system which consists of robust profiles actioned by extension pantographs and PVC shade top covers of any type (meshed, transparent, opaque, ...)

La versione "Parasole" della pergola standard prevede l'installazione, nella parte interna della struttura, di un sistema semovibile costituito da robusti profili movimentati da un sistema a pantografo estensore e teli in qualsiasi tipo di tessuto o telo PVC (retinato, cristal, oscurante, ...).

FASTENING SYSTEM SISTEMA D'AGGANCIO

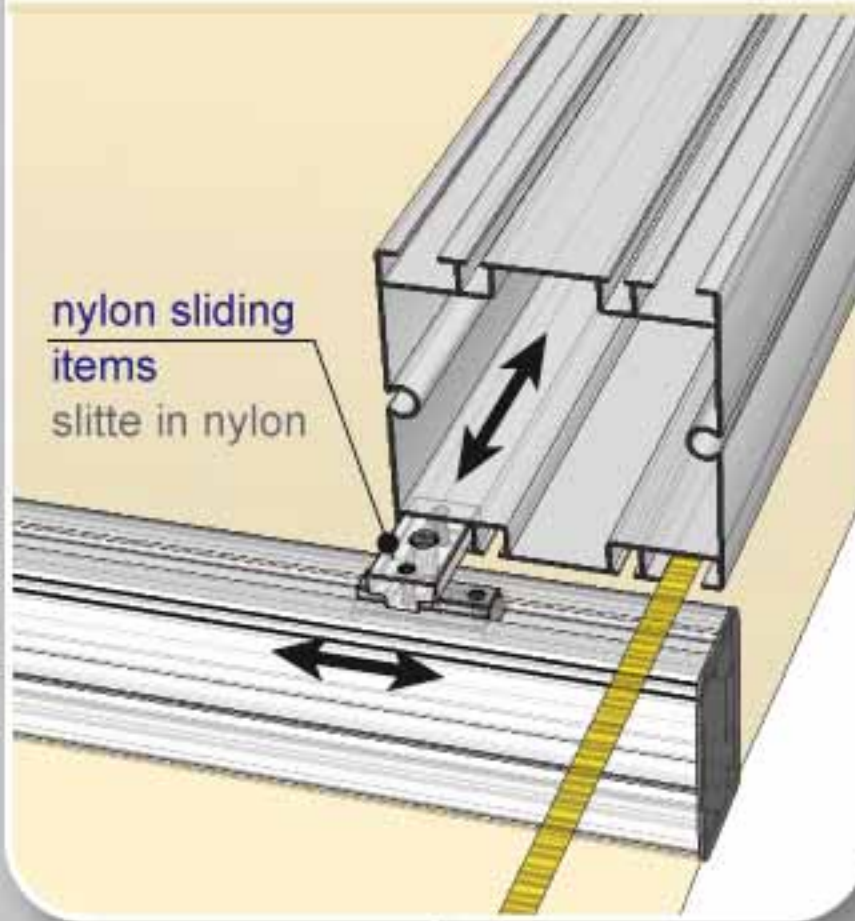

DIMENSIONS DIMENSIONI

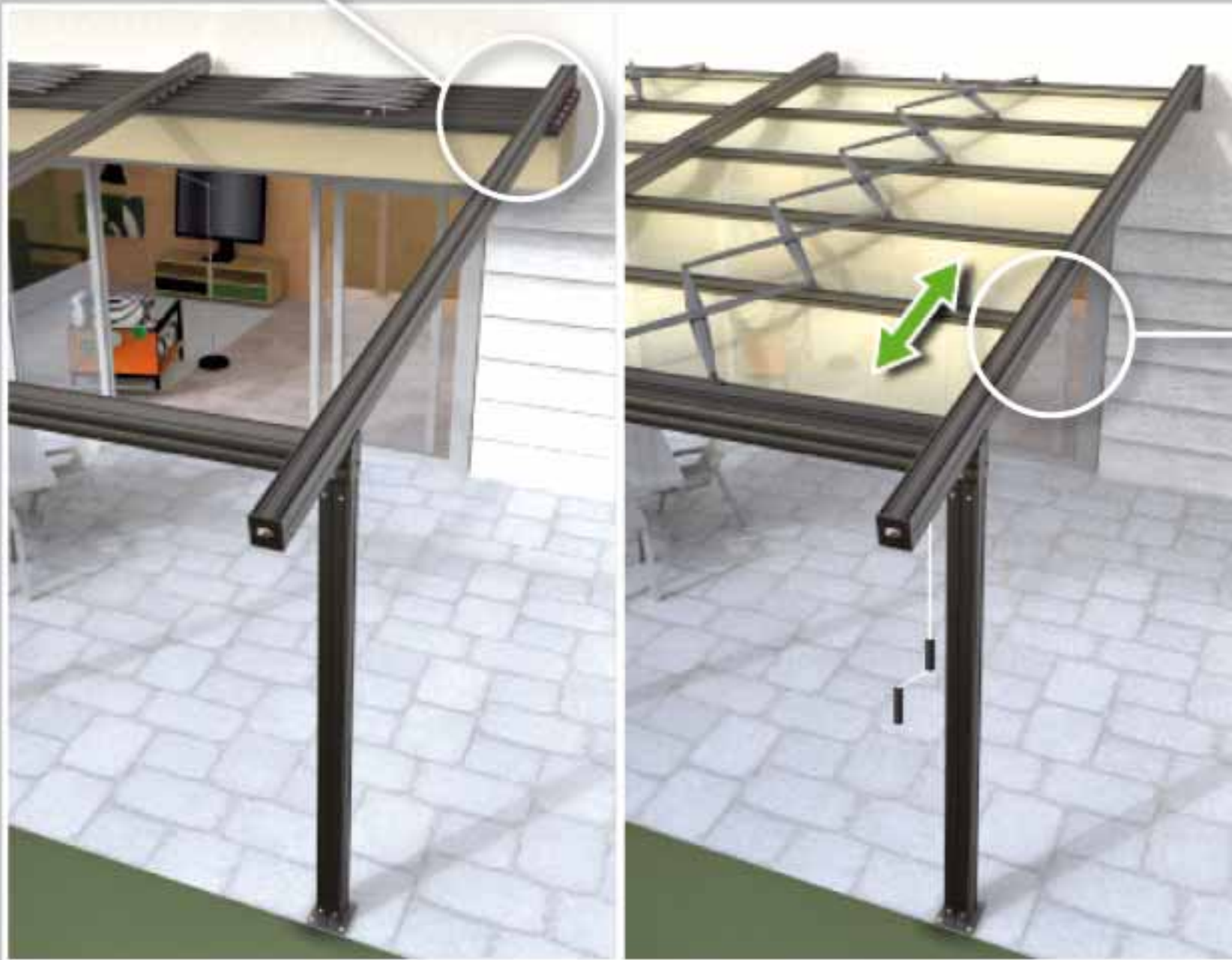
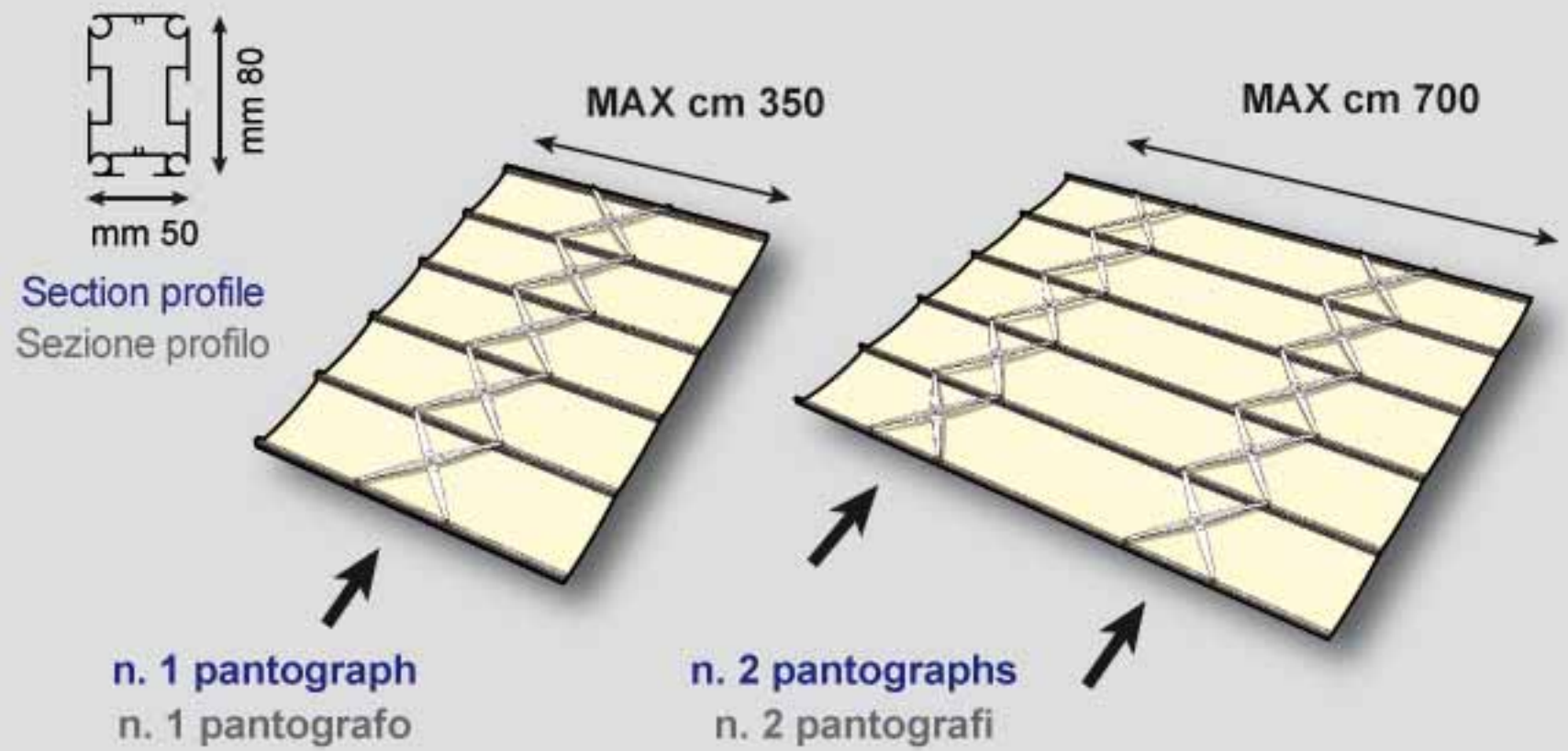

STANDARD MANUAL OPENING-CLOSING SYSTEM SISTEMA DI MOVIMENTAZIONE MANUALE

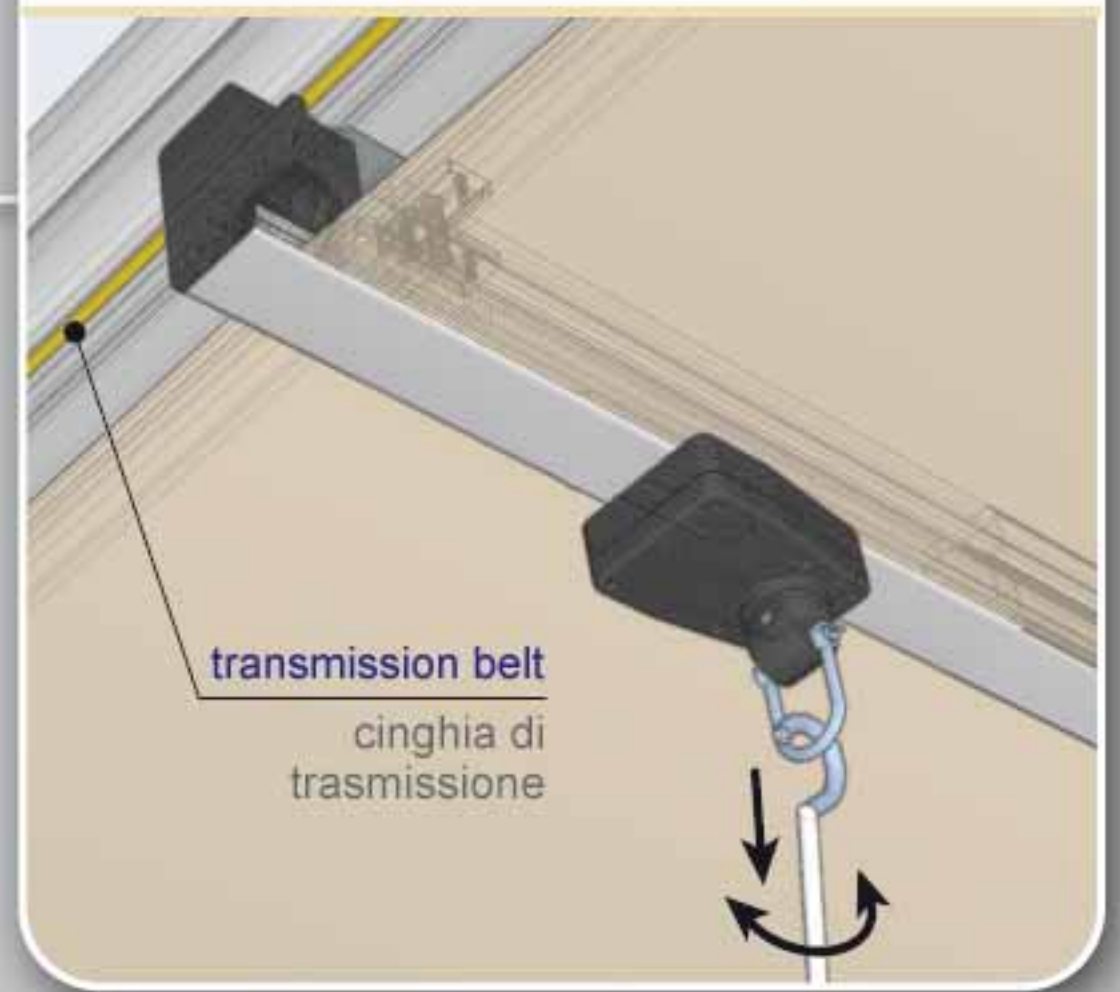

ON REQUEST, THE FOLDING SYSTEM CAN BE ALSO MOTORIZED (SEE OPTIONAL ITEMS)
A RICHIESTA LA COPERTURA POTRÀ ESSERE MOTORIZZATA (VEDI OPTIONALS)



COVERING SYSTEM SISTEMA DI COPERTURA

3 FACILE

Special Pergola System

APRI & CHIUDI
PARAPIOGGIA



OPEN & CLOSE
RAIN PROTECTION

The Rain Protection version foresees the installation, on the exterior side of the top cover of a mobile system which consists of robust profiles actioned by extension pantographs and rain proof PVC.

La versione "Parapioggia" della pergola standard prevede l'installazione, nella parte esterna della struttura, di un sistema semovibile costituito da robusti profili in alluminio movimentati da un sistema a pantografo estensore e teli in PVC impermeabili alla pioggia.

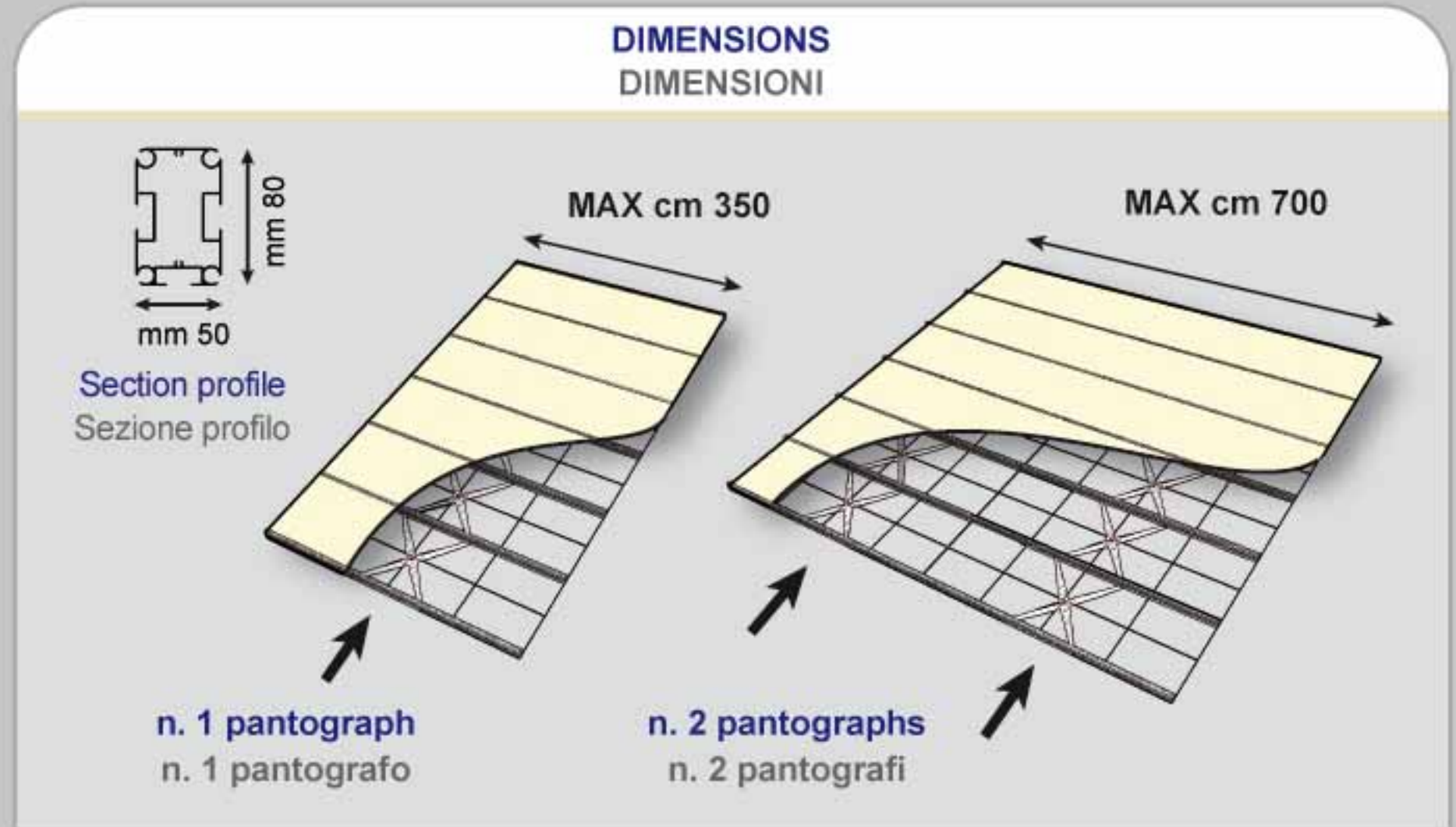

ON REQUEST, THE FOLDING SYSTEM CAN BE ALSO MOTORIZED (SEE OPTIONAL ITEMS)
A RICHIESTA LA COPERTURA POTRÀ ESSERE MOTORIZZATA (VEDI OPTIONALS)



OPEN & CLOSE
SUN PROTECTION
RAIN PROTECTION

APRI & CHIUDI
PARASOLE
PARAPIOGGIA

Both the Sun protection and the Rain protection versions can be installed on the same aluminium frame. In this way it is possible, with a simple movement, to adapt your Pergola System to all weather conditions and fully enjoy the space covered by this versatile, comfortable and intelligent structure.

Sulla stessa struttura è possibile installare sia la copertura "parapioggia", che la copertura "parasole"; in questo modo sarà possibile, con un semplice gesto, adattare la vostra pergola a qualsiasi condizione atmosferica e godere a pieno del vostro nuovo spazio allestito con questo prodotto versatile, confortevole ed intelligente!



OPEN & CLOSE

APRI & CHIUDI

CLOSING ALUMINIUM GUTTER
GRONDAIA IN ALLUMINIO

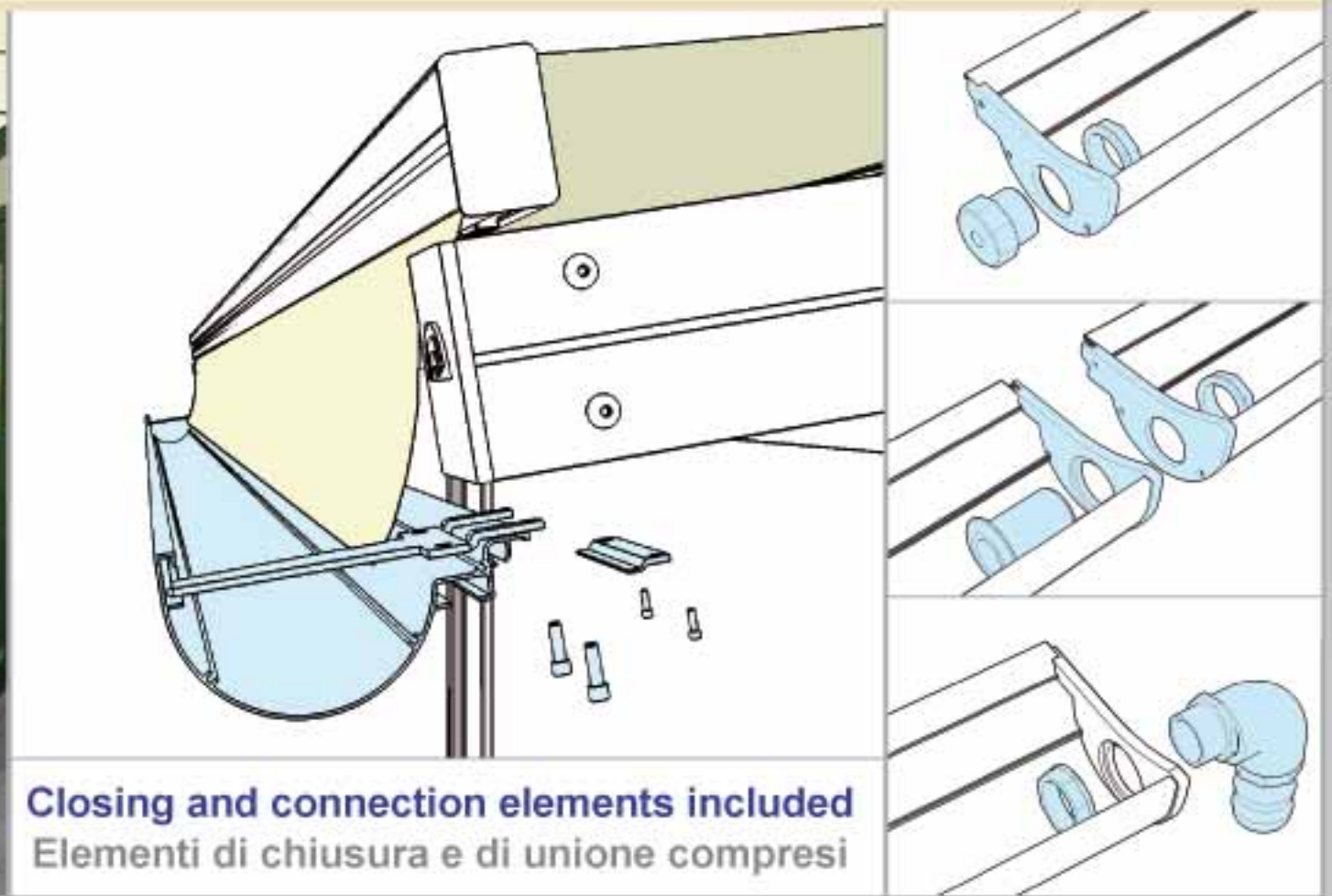

RIDGE CAP
SCOSSALINA A PARETE

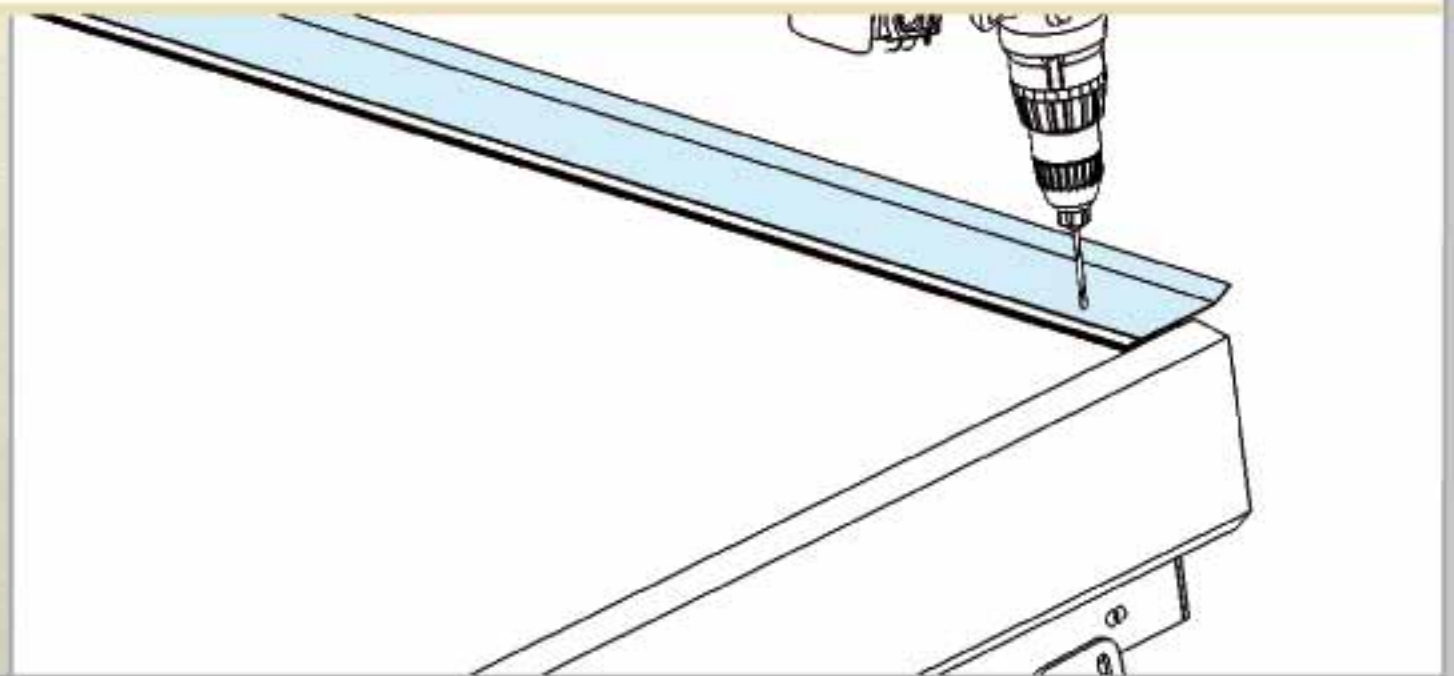
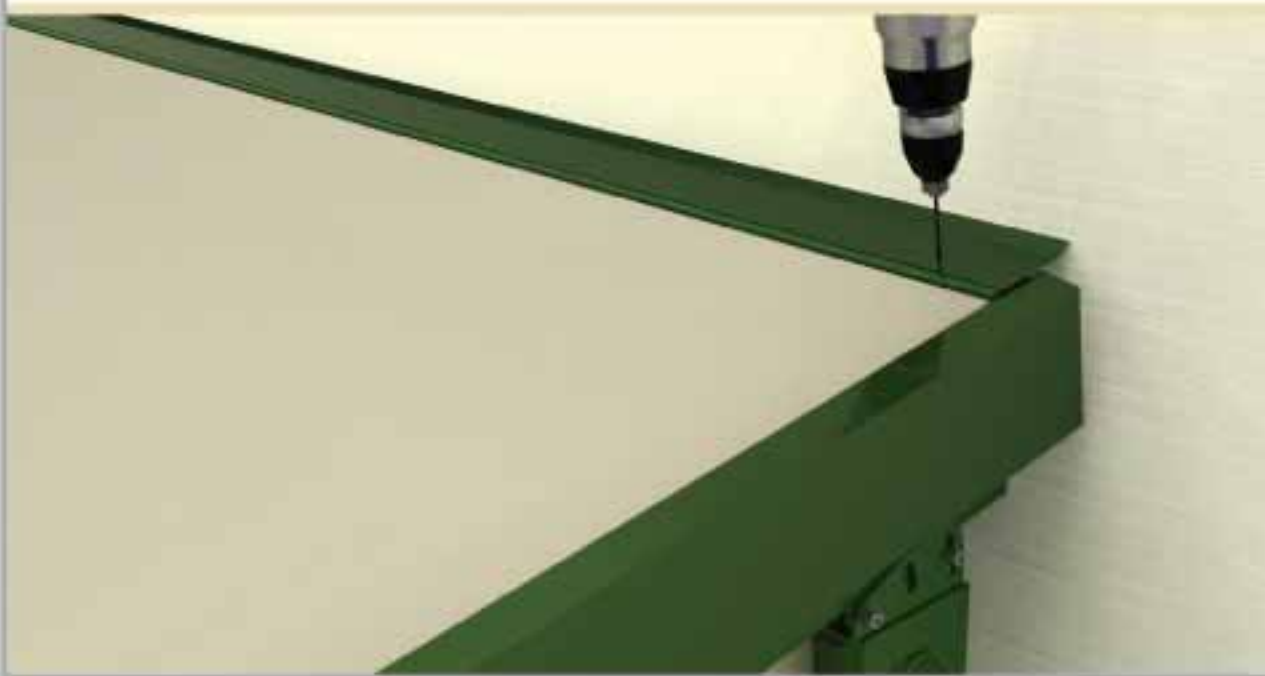

MOTORIZED SYSTEM
SISTEMA MOTORIZZATO

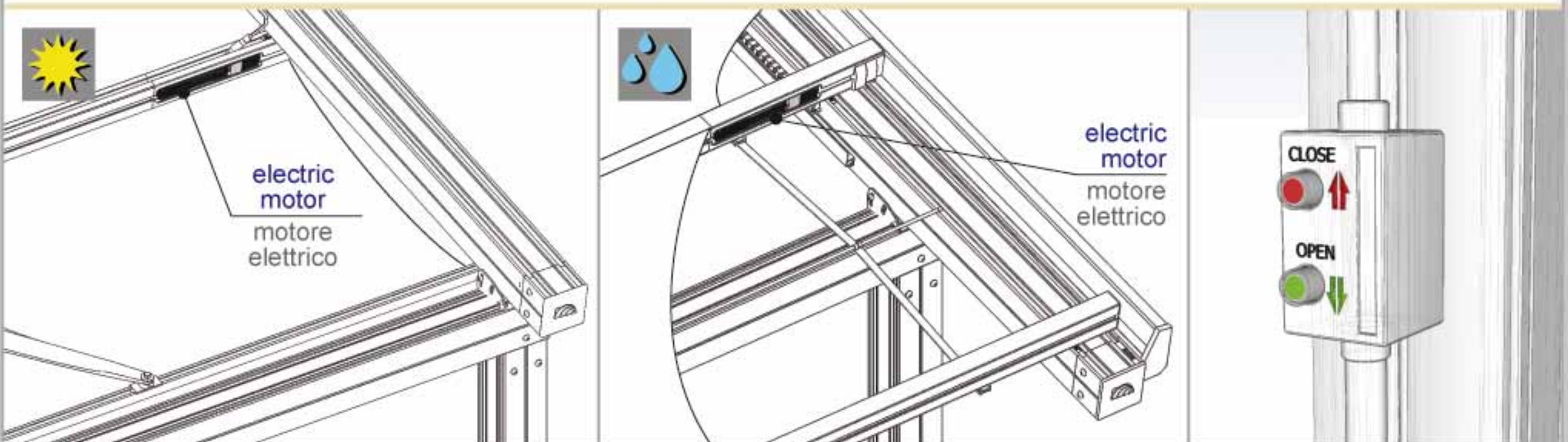



3 Facile Open&Close it's a reliable, safe and versatile product, suitable to cover and protect different types of exterior spaces. The innovative and elegant design allows the installation of the pergola in any type of architectural context.

It is possible to customize the structure thanks to a wide range of colours and enlarging its use by installing side walls, made either in PVC or rigid material, in order to take advantage of the whole exterior space in all the seasons.

3 Facile Apri&Chiudi è un prodotto affidabile, versatile e sicuro adatto a coprire e proteggere aree esterne di vario genere.

Il design innovativo ed elegante rende la pergola adatta ad essere installata in qualsiasi contesto architettonico.

È possibile personalizzare la struttura grazie ad un'ampia scelta di colori disponibili ed ampliare le possibilità di utilizzo grazie all'installazione di pareti perimetrali, sia in pvc che in materiale rigido, per sfruttare l'area esterna in qualsiasi stagione.



GIULIO BARBIERI
Special Modular Coverings

Giulio Barbieri S.p.A.
Via Ferrara, 41.
44028 Poggio Renatico (FE).
Tel. (+39) 05 32 82 15 11
Fax. (+39) 05 32 82 15 55

